

Universal Plus basement drain ver., black, Backw.valve, Waterpr.concr.

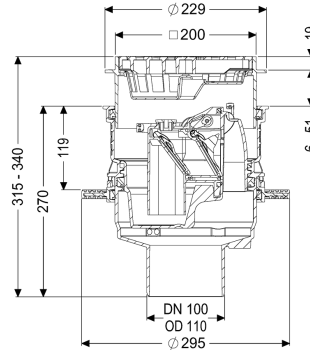
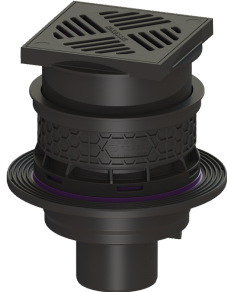

Article information

Item no.: 27631
 GTIN: 4026092096864
 Price group: 10

Advantages

- Sustainable due to use of recycled material
- Inlets above the floor slab, no penetration required
- Vertical outlet for easy installation and easy access to the main drainage pipe

Description

The polymer Universal Plus basement drain is used for drainage of non-faecal wastewater and is equipped with a removable backwater valve with two backwater flaps and a one hand-lockable emergency closure. Including temporary protective cover. The drain is pressure-waterproof up to 0.6 bar (MFPA Leipzig tested) and radon-tight (IAF Radioökologie GmbH tested).

Variant

Contents of sludge trap:	yes
Emergency closure:	yes
Waterproof flange:	Pre-assembled at the factory
Sealing water height:	60 mm
Discharge rate (l/s) with 10 mm threshold:	1,4
Discharge rate (l/s) with 20 mm threshold:	1,9
Mechanical backwater flaps:	2

General characteristics

Colour:	black
Standard:	EN 1253
Nominal size (DN):	100
Type of wastewater:	without sewage
Installation situation:	floor slab installation

Backwater protection:	Type 5
Dimensions	
Net weight:	3,21 kg
Gross weight:	3,62 kg
Diameter:	295 mm
Cutout dimension, width:	310 mm
Cutout dimension, length:	310 mm
Adjustment range:	23 - 80
Installation depth:	293 - 350 mm
Type of height adjustability:	vertically adjustable upper section
Height:	270 mm
Packaging dimension:	length
Packaging dimension:	width
Packaging dimension:	height
Tank/drain body	
Socket version:	vertical
Coverage features	
Type of cover:	Slotted cover
Cover material:	Polymer
Colour of cover:	black
Width of cover:	200 mm
Height of cover:	25 mm
Length of cover:	200 mm
Load class:	K 3 (EN 1253-1)
Contents of sludge trap:	yes