

Aqualift S Compact lift stat. Tronic, GTF 500, resistant, Floor slab

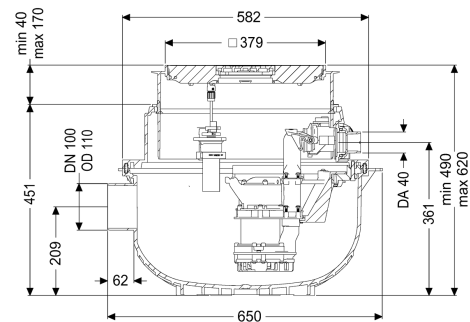

Article information

Item no.: 280550SC
 GTIN: 4026092082669
 Price group: 20

Advantages

- Space-saving due to installation in floor slab with integrated drainage function
- Easy retrofitting from Mono to Duo possible
- Quiet operation, as the pump installation does not cause any structure-borne sound emissions.

Description

The ready to plug in lifting station for faecal-free wastewater is equipped with one or two submersible pumps and a backflow preventer. The collection tank made of permanently resistant polymer (PE) has an open pump tank. One-handed closures enable easy removal of the integrated components. The system for installation in the floor slab is preassembled for final installation on site.

Variant

Type of system:
 Resistant:

Single unit
 Resistant to saline media, wastewater from water softening systems and wastewater containing condensate from heating systems

Pump control:
 Backflow preventer:

Control unit
 integrated

General characteristics

Colour:
 Standard:
 Type of wastewater:
 Installation situation:
 Delivery state:

black
 EN 12050-2
 without sewage
 floor slab installation
 Installation-ready (connection parts must be connected on site)

System type:

Tronic

Dimensions

Net weight:	17,31 kg
Gross weight:	18,81 kg
Groundwater resistant from lower edge of base section:	3000 mm
Installation depth:	490 - 620 mm
Type of height adjustability:	vertically adjustable upper section
Length:	617 mm
Width:	585 mm
Packaging dimension:	length
Packaging dimension:	width
Packaging dimension:	height

Tank/drain body

Pressure pipe connection (DN):	32
Pressure pipe connection (OD):	40 mm
Inlet nominal size (DN):	100 mm
Pumping volume:	20 l

Coverage features

Type of cover:	Cover plate with slotted cover
Cover material:	Polymer
Colour of cover:	black
Width of cover:	366 mm
Length of cover:	366 mm
Locking:	Lock & Lift
Load class:	K 3 (EN 1253-1)

Pumping device

Pump:	GTF 500 resistant
Number of pumps:	1
Connection type:	coded plug
Protection class (pump):	IP 68 (3m)
Temperature monitoring:	integrated
Max. temperature (permanent) of conveyed material:	40 °C
Hot water resistance for a short time (2 min):	80 °C
Max. pumping capacity:	10 m ³ /h
Max. pumping height:	8 m
Speed:	2800 U/min
Power P1:	0,6 kW
Power P2:	0,36 kW
Operating mode:	S1
Type of pump connection cable:	H07RN-F 3G 1.5 mm ²
Impeller type:	Multi-vane impeller
Free passage:	10 mm
Length of mains cable for pump:	5 m
Rated current:	2,7 A

Control	
Control unit:	Comfort
Alarm sensor:	optical probe
Level measurement instrument:	Immersion pipe
Type of level measurement:	pneumatic
Protection class control unit:	IP 54
Mains frequency:	50 Hz
Operating voltage:	230 V
Connection type:	coded plug
Length of mains cable for control unit:	1,4 m
Potential-free contact:	optional
GSM interface:	yes
USB interface:	yes
Log book function:	yes
Multi-line display:	yes
Battery buffering:	yes
Self-diagnosis system (SDS):	yes
Type of fuse required (electrical protection):	C 16 A