

Lifting station Minilift F Free-standing set-up

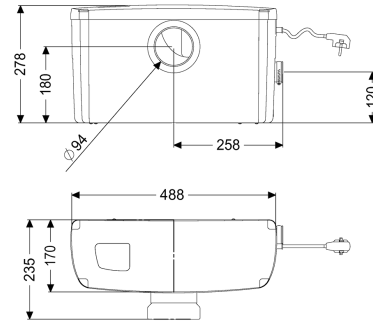
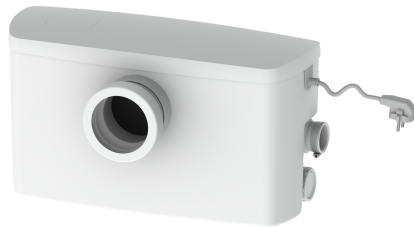

Article information

Item no.: 28520
 GTIN: 4026092072899
 Price group: 20

Advantages

- High-performance cutting unit SharkTwister
- Intelligent control technology
- Easy maintenance

Description

The ready to plug in small lifting station for faecal and faecal-free wastewater is suitable for the wastewater drainage of individual toilets. The collection tank made of polymer (ABS) is equipped with a backflow preventer, an activated carbon filter, an alarm function, a horizontal inlet DN 100 and two horizontal inlets DN 40. The integrated control unit controls the small lifting station via pneumatic level measurement.

Variant

Type of system:	Single unit
Backflow preventer:	integrated
Pressure pipe connection:	horizontal

General characteristics

Colour:	white
Standard:	EN 12050-3
Type of wastewater:	with sewage
Installation situation:	free-standing installation
Delivery state:	plug-in ready

Dimensions

Net weight:	7,33 kg
Gross weight:	7,53 kg
Length:	488 mm
Width:	237 mm
Height:	285 mm

Packaging dimension:	length
Packaging dimension:	width
Packaging dimension:	height
Tank/drain body	
Pressure pipe connection (OD):	28 mm
Distance from centre of outlet pipe to tank bottom:	108 mm
Distance from centre of inlet pipe to tank bottom:	180 mm
Inlet nominal size (OD):	110 mm
Inlet nominal size (DN):	100 mm
Number of inlets:	3
Pumping volume:	4 l
Tank volume:	11 l
Pumping device	
Number of pumps:	1
Connection type:	Schuko (earthed contact) 2-pin
Rated current:	2,8 A
Protection class:	I
Protection class (pump):	IP 44
Temperature monitoring:	integrated
Max. temperature (permanent) of conveyed material:	35 °C
Hot water resistance for a short time (2 min):	80 °C
Max. pumping height:	6,4 m
Speed:	2900 U/min
Power P1:	0,65 kW
Power P2:	0,35 kW
Operating mode:	S3 - 30 %
Type of pump connection cable:	H03 VV-F 3G 0.75 mm ²
Impeller type:	Macerator
Length of mains cable for pump:	1,6 m
Control	
Type of level measurement:	pneumatic
Operating voltage:	230 V
Connection type:	Schuko (earthed contact) 2-pin