

Lifting station Aqualift F Comp. Mono, SPZ 1000, res. Floor sl., tileable

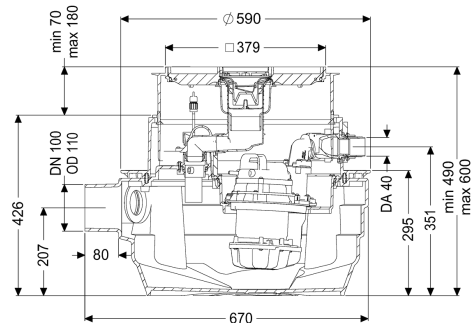

Article information

Item no.: 28701XC
 GTIN: 4026092093641
 Price group: 20

Advantages

- Suitable for complete basement drainage
- Integrated drainage function when installed in the floor slab
- Maximum operating reliability due to intelligent control unit (Duo)

Description

The lifting station for faecal and faecal-free wastewater is equipped with one or two submersible pumps and a backflow preventer. The collection tank made of permanently resistant polymer (PE) has an enclosed pump tank. One-handed closures enable easy removal of the integrated components.

Variant

Type of system:

Shut-off valve:

Resistant:

Pump control:

Backflow preventer:

Pressure pipe connection:

Single unit

without shut-off valve

Resistant to saline media, wastewater from water softening systems and wastewater containing condensate from heating systems

Control unit

integrated

horizontal

General characteristics

Colour:

Type of wastewater:

Installation situation:

black

with sewage

floor slab installation

Delivery state:	Pre-mounted for final assembly on site (pumps and sensor system must be fitted on site and control unit must be connected)
Approval:	Z-53.2-484
System type:	Mono
Odour trap:	Multistop
Dimensions	
Net weight:	32,5 kg
Gross weight:	37,5 kg
Groundwater resistant from lower edge of base section:	3000 mm
Cutout dimension, width:	800 mm
Cutout dimension, length:	800 mm
Installation depth:	490 - 600 mm
Type of height adjustability:	vertically adjustable upper section
Length:	670 mm
Width:	590 mm
Packaging dimension:	length
Packaging dimension:	width
Packaging dimension:	height
Tank/drain body	
Pressure pipe connection (DN):	32
Pressure pipe connection (OD):	40 mm
Connection conduit pipe (DN):	50
Venting connection (DN):	70
Distance from centre of outlet pipe to tank bottom:	351 mm
Distance pipe bottom outlet to tank bottom:	351 mm
Distance pipe bottom inlet to tank bottom:	152 mm
Distance from centre of inlet pipe to tank bottom:	207 mm
Inlet nominal size (OD):	110 mm
Inlet nominal size (DN):	100 mm
Number of inlets:	1
Pumping volume:	20 l
Tank volume:	40 l
Coverage features	
Type of cover:	tileable cover plate
Cover material:	Polymer
Width of cover:	366 mm
Length of cover:	366 mm
Drainage function:	yes
Locking:	Lock & Lift
Max. flooring height:	16 mm
Pumping device	
Pump:	SPZ 1000 resistant

Number of pumps:	1
Weight, pump:	10 kg
Connection type:	coded plug
Rated current:	5,2 A
Protection class:	I
Insulation class:	F
Cos phi - power factor:	0,97
Protection class (pump):	IP 68
Temperature monitoring:	integrated
Max. temperature (permanent) of conveyed material:	40 °C
Hot water resistance for a short time (2 min):	80 °C
Max. pumping capacity:	11,5 m ³ /h
Max. pumping height:	10 m
Speed:	2800 U/min
Power P1:	1,2 kW
Power P2:	0,69 kW
Operating mode:	S3 - 50 %
Type of fuse required (electrical protection):	Fuse protection through control unit 230 V
Type of pump connection cable:	H07RN-F 3G 1.5 mm ²
Impeller type:	Macerator
Length of mains cable for pump:	5 m
Control	
Control unit:	Comfort
Control unit function:	With alarm message
Motor protection switch:	yes
Alarm sensor:	optical probe
Level measurement instrument:	Immersion pipe
Type of level measurement:	pneumatic
Protection class control unit:	IP 54
Mains frequency:	50 Hz
Operating voltage:	230 V
Connection type:	coded plug
Length of mains cable for control unit:	1,4 m
Potential-free contact:	optional
GSM interface:	yes
USB interface:	yes
Log book function:	yes
Multi-line display:	yes
Battery buffering:	yes
Self-diagnosis system (SDS):	yes
Warning equipment version:	acoustic and optical signal
Type of fuse required (electrical protection):	Fuse protection through control unit 230 V