

Grease separator EasyClean free Basic, NS2, Direct, right, wind., Refill

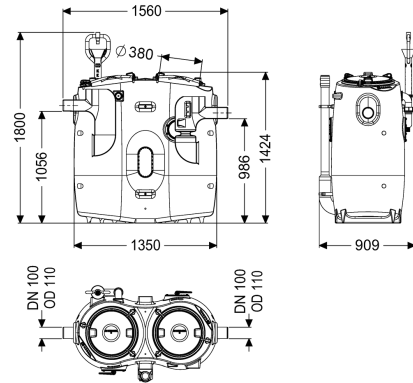

Article information

Item no.: 94002.32DR
 GTIN: 4026092084359
 Price group: 60

Advantages

- Odour-reduced disposal with the tank closed
- Low-maintenance operation

Description

The separator for greasy wastewater is suitable for free-standing set-up in frost-protected rooms and comes without metallic components in the tank. The collecting tank made of permanently resistant polymer (PE) is equipped with an integrated sludge trap. Two odour-tight covers with quick-release closures allow for easy access for cleaning and maintenance work. There is a direct disposal pipe socket available for odour-reduced manual disposal. After disposal, a maximum of 3 litres residual sludge volume is left in the tank. 20 year polyethylene warranty.

Variant

Direction of flow:	right
Disposal variant:	Direct
Sludge bucket:	yes
Nominal size (NS):	2
Refill inlet in accordance with DIN 1988:	yes
Type of disposal:	manual
Load-bearing capacity (DIN 19901):	F3

General characteristics

Material:	PE
Standard:	EN 1825
Installation situation:	free-standing installation
Delivery state:	Installation-ready (connection parts must be connected on site)

Scope of delivery:	Storz-B coupling R 2 1/2" for disposal vehicle connection
Dimensions	
Net weight:	83 kg
Gross weight:	108 kg
Set-up area, length:	1560 mm
Set-up area, width:	920 mm
Set-up area, height:	1800 mm
Required access area, length:	1560 mm
Required access area, width:	745 mm
Required access area, height:	1420 mm
Packaging dimension:	length
Packaging dimension:	width
Packaging dimension:	height
Tank/drain body	
Nominal pressure (PN):	10
Pressure pipe connection (DN):	65
Pressure pipe connection (OD):	75 mm
Distance pipe bottom outlet to tank bottom:	985 mm
Distance pipe bottom inlet to tank bottom:	1055 mm
Outlet nominal size (OD):	110 mm
Outlet nominal size (DN):	100 mm
Inlet nominal size (OD):	110 mm
Inlet nominal size (DN):	100 mm
Connection inlet/outlet sockets:	PE-HD pipes in accordance with DIN 19537, HT pipes in accordance with DIN 19560, PP or AS
Coverage features	
Type of cover:	Cover
Cover material:	Polymer
Colour of cover:	violet
Locking:	Quick-release closure
Tightness:	odour-tight
Wastewater contents	
Max. grease layer thickness:	120 mm
Total volume:	660 l
Contents of sludge trap:	200 l
Storage quantity of grease:	80 l